

LOTUS EUROPA

OWNER'S HANDBOOK

LOTUS CARS (Service) LTD. Norwich Norfolk Nor. 92W England

Telephone: Wymondham 3411

Telex: 97401

Cables Lotus Norwich

Part No. 54T324

© LOTUS CARS LTD 1966

INDEX

Ammeter	8	Jack	14
Ashtray	10	Lamps switch	5
Battery	12	Locks and keys	11
Body care	15	Lubrication	17
Brakes	16	Lubrication diagram	23
Choke	11	Oil pressure gauge	7
Direction indicator switch	5	Recommended lubricants	22
Face level ventilators	9	Running-in	12
Facia panel	6	Safety	4
Fault diagnosis	26, 27	Seats	10
Foot controls	9	Service notes	20
Foreword	4	Servicing	12
Frost precautions	15	Specifications	24
Fuel gauge	7	Speedometer	8
Gearshift lever	9	Starting procedure	11
Genuine parts	20	Steering column adjustment	11
Handbrake	9	Storage	20
Headlamps dipswitch	5	Tachometer	8
Heater controls	8	Tyres	15, 24
Heater fan switch	9	Vehicle identification	4
Horn	5	Water temperature gauge	7
Ignition/starter switch	5	Wheel removal	14
Ignition warning lamp	5	Window lift switches	8
Interior lamp switch	7	Windscreen wiper switch	7

FOREWORD

This handbook, which covers various specifications based on one model, has been compiled to give you, the owner, the essential information which you require. It is in no way intended to give all the technical information required, and, should any work become necessary which is not detailed in it, owners are strongly recommended to contact a Lotus Dealer.

The normal periodic services required by your vehicle is at intervals of 5,000 km. (3,000 miles). These services are given in the Service Voucher Book (Part No. 46T 326) which is included in your car on purchase. Owners are requested to adhere to the recommended service at each mileage interval, otherwise the Warranty could be invalidated.

Please read this handbook and keep it in the car.

In line with our policy of continuous product improvement, we earnestly recommend that, in your own interest, you keep in regular contact with your Lotus Dealer, in order that he may acquaint you with any technical developments or improvements that have been made to subsequent vehicles, which would improve the performance of your own vehicle.

We reserve the right to change prices, specifications and equipment at any time without notice.

Safety

The Europa has been built with safety in mind and incorporates "in-built" safety features.

Some of these features are:— excellent visibility including a very low bonnet line. Powerful front disc brakes giving repeated high performances with light pedal action, capable of exceeding .9g retardation. Light, accurate, high-g geared steering requiring the minimum of movement to change direction. Excellent road-holding and very high cornering ability, capable of exceeding .8g lateral side load, vivid acceleration ensuring rapid overtaking with the minimum of delay.

It is pointed out that as with all things, there is an ultimate. This particularly applies to road-holding, therefore, the car should be driven at all times within the capabilities of your own experience.

Vehicle Identification

The unit number (which is also the chassis number), engine and transmission numbers will be found on a plate fixed to the rear wall of the front luggage compartment. The engine number is duplicated on the side of the cylinder block below the exhaust manifold, adjacent to the starter motor. The transmission number will be found on top of the rear cover, adjacent to mounting block.

It is essential that these numbers are quoted in all correspondence.

4

INTRODUCTION TO THE VEHICLE

This chapter outlines the various controls and instruments, explaining the function of each. It is hoped that both service engineer and owner will familiarize themselves with the vehicle's controls and instruments and their layout. The number references relate to the facia panel illustrated on page 6.

17 Combined ignition/starter switch

Turn key to the right to switch on the ignition, and turn further to the right, against spring pressure, to operate the starter. When the engine starts, the key should be released, whereupon it will spring back to the "ignition on" position.

If it is required to operate the radio (13), when fitted, with the engine stationary, the ignition key should be turned to its extreme left position.

4 Ignition warning lamp

The ignition warning lamp glows red when the ignition is switched on and will go out when the alternator is charging. It may glow when the engine is idling, but no harm will be done as long as the engine is running.

The warning lamp must not be allowed to glow for more than a few moments with the engine stationary, otherwise the battery will discharge itself through the ignition coil.

22 Choke control

Instructions for using the choke control will be found under the heading "Starting Procedure".

9 Combined side, rear, tail and headlamp switch

The switch is pressed down to the halfway position to switch on the side, rear and tail lamps, and fully down to energize the headlamps.

27 Direction indicators

When turning to the left or to the right, move the control lever UP or DOWN as appropriate. A warning lamp (8) on the facia will flash in unison with the lamps. Bulb failure on one side of the car will be indicated by the warning lamp either failing to flash, or to flash rapidly.

31 Headlamps dipswitch

Main beam is obtained with the lever in the upper position; to select dipped beam move the control lever down. Lifting the lever towards the steering wheel flashes the headlamps main beams.

When the headlamps are on main beam a warning lamp (5) on the facia will illuminate.

29 Horns

The horns are operated by pressing the central button of the steering wheel.

5

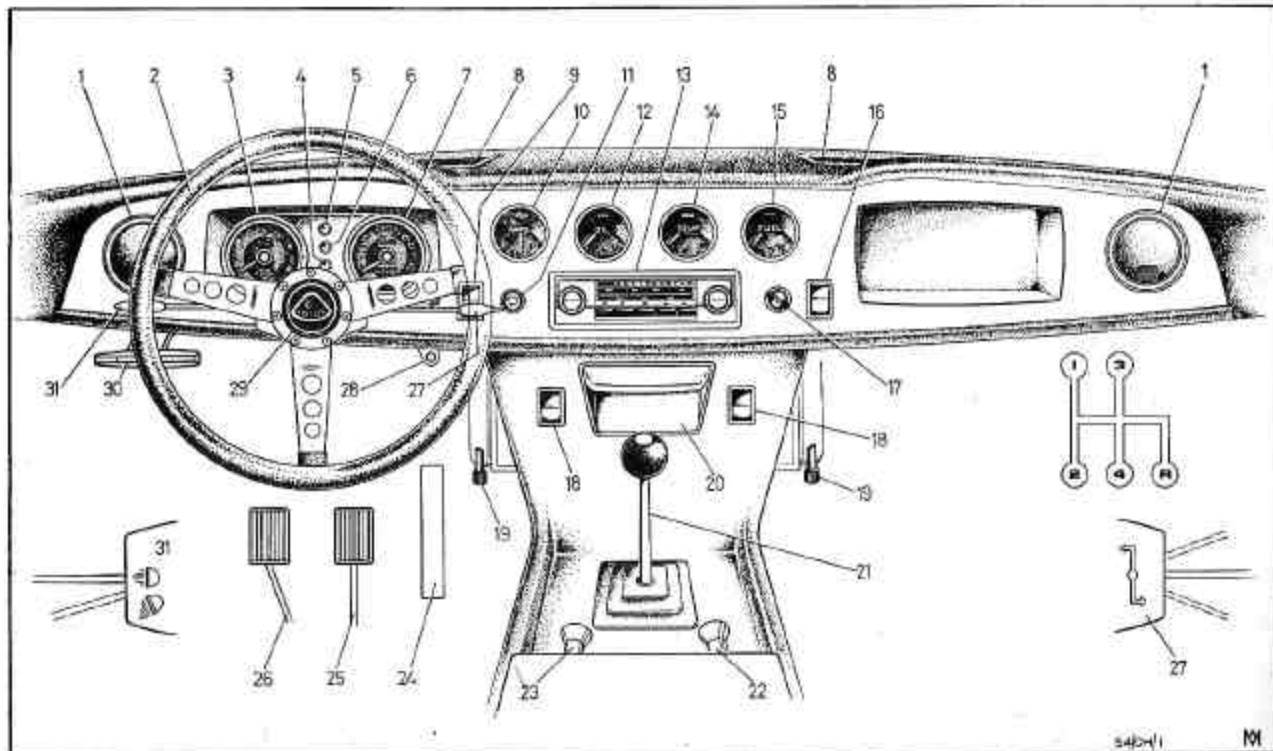

Fig. 1. Facia Panel and controls
6

11 Combined "2-speed" windscreen wiper/washer control

To operate the windscreen wipers, rotate the wiper knob in a clockwise direction to the "ON" position. If desired, the wiper speed can be increased by turning the knob further to the right.

If the blades become obstructed by, for example, ice or packed snow on the windscreen, the wipers should be switched "OFF" to prevent damage to the internal mechanism, the obstruction cleared, and the wipers then switched on again.

To use the screen washers, fully depress and release the control. The use of a proprietary additive to the washer bottle is recommended providing it contains nothing to harm the windscreen sealing rubber, windscreen wiper blades or body paintwork. DO NOT use radiator anti-freeze, as this may damage the paintwork.

Interior lamp switch

The lamp is located between the seat headrests with the switch incorporated in its body.

The lamp will illuminate automatically when either door is opened through courtesy switches in the door pillars. The lamp can be switched on by hand when the doors are shut, but cannot be switched off if the doors are left open.

12 Oil pressure gauge

Should normally register a pressure of 4.2 kg. cm.² (60 lbs. in.²) under normal running conditions. The indicated pressure will fall to between .35/1.4 kg. cm.² (5/20 lbs. in.²) when the engine is idling.

If the gauge fails to register, the engine must be stopped at once and the cause sought and rectified before restarting the engine, otherwise serious damage may result.

14 Water temperature gauge

This instrument registers the engine coolant temperature and will give a reading of approximately 85° C. under normal running conditions.

It should be noted that although the boiling point of water is 100° C., with the pressurized system used of .49 kg. cm.² (7 lbs. in.²) the boiling point of water is raised to 111.6° C., at sea-level, so there is no cause for undue alarm should the temperature rise slightly above the optimum 85° C. (approx.).

15 Fuel gauge

The fuel gauge is operative when the ignition is switched "ON" and indicates the approximate amount of fuel in the 7½ Imperial gallons (9 U.S. gallons; 34 litres) tank.

10 Ammeter

The ammeter indicates the rate at which the alternator is charging the battery. It must be noted that as the battery nears its fully charged condition the rate of charge will diminish.

7 Speedometer

This instrument indicates the vehicle's speed and incorporates both a total distance recorder and a cancelling trip recorder.

The trip recorder is cancelled back to zero by pushing the milled knob (28) located beneath the speedometer head under the fascia, in an upwards direction and turning clockwise. After resetting pull the knob down.

3 Tachometer

The tachometer is of the electrical type and gives an indication of the engine's revolutions per minute.

Maximum safe continuous engine speed is 6,000 r.p.m., which is indicated by the orange sector. It is permissible to use up to 6,300 r.p.m. for short bursts, but speeds in excess of this **MUST NOT BE USED.**

18 Window lift switches

The door windows are operated electrically by the rocker switches located in the centre of the fascia panel below the radio aperture, left-hand switch for left-hand window, and right-hand switch for right-hand window. Press down and hold to lower the windows, pushing up and holding to raise the windows, releasing when window reaches its limit.

The switches are in the constant live position, thus enabling the windows to be operated without switching "on" the ignition.

If difficulty is experienced in raising or lowering the windows in extreme cold conditions, this can be remedied by using a de-freezing fluid around the window seals. **DO NOT** use a radiator anti-freeze solution as this could have disastrous effects on the window seals and body paintwork.

19, 23 Heater controls

Interior ventilation and heating can be controlled in the following manner to suit your requirements and can operate satisfactorily with the windows closed thus reducing wind noise to a minimum. Air can be delivered, hot or cold and at any intermediate temperature, to the screen (8) or to the car interior (19) depending upon requirements.

6

Temperature is controlled by pulling out the knob (23) (from the cold position when fully in) to the hot in the fully extended position.

The demisters are fed with air at all times, but in order to dispel heavy misting, or to defrost the screen, close the flaps (19) on either side of the heater unit under the fascia, by actuating the white toggles on these flaps with a sideways motion.

16 Heater fan switch

The fan ("heat") switch is three-positional: up—"off"; centre—"plenum chamber fan"; lower—"plenum chamber and radiator fan".

When used in conjunction with the heater controls, the fan will deliver a greater quantity of air to either "screen" or "interior" of car at any temperature between "cold" and "hot".

1 Face level ventilators

This system is entirely independent from the normal screen and interior ventilation, although both systems can be used at the same time. If the heater fan is not operating then the system will operate by means of simple ram effect, delivering air at ambient temperature.

Direction of the vents is by pushing with the finger and thumb to the desired position. Open or close vents by pushing with finger.

30 Handbrake

The handbrake lever is under the lower edge of the fascia panel to the left of the steering column.

To release, pull lever slightly rearwards (as when pulling "on") at the same time press the release trigger in the hand grip with the thumb, then push the lever fully forward to the "off" position.

21 Gearshift lever

The gear lever is centrally situated and comes readily to hand. First and second gears are selected by moving it to the left and engaged by moving it forwards for the first gear and backwards for second gear. Third and fourth gears are selected by moving the lever to the right and through neutral position until resistance is felt, then forwards for the third gear and backwards for fourth gear.

To engage reverse gear, move the lever to the right in the neutral position until resistance is felt, push the lever against the spring pressure and then move it rearwards until the stop is reached to engage the gear.

Foot controls

The foot controls are arranged in the orthodox position—namely the clutch pedal (26), brake pedal (25), and accelerator pedal (24), reading

9

from left to right. Owners are reminded not to drive with their left foot resting on the clutch pedal. It is a bad practice and leads to rapid release bearing wear. It is also inadvisable to pump the accelerator pedal when the engine is not running as this causes flooding of the carburettor and subsequent difficulty in starting.

After negotiating a ford, or when driving on flooded roads, it may be necessary to dry out the brakes to restore full braking power by a few light applications of the brake pedal. It is also advisable to do this after or during prolonged driving in wet weather, under circumstances where the brakes are not in use, such as may occur on high-speed motorways, etc.

20 Ashtray

The ashtray in the fascia is opened by pulling the horizontal handle. The bin is removed for emptying by depressing the spring clip, visible when the ashtray is in the fully open position.

Rear view mirror

The rear view mirror is adjustable for height by turning through 180°.

Seats

The seats are adjustable in both a fore and aft direction by pushing the catch located at the front.

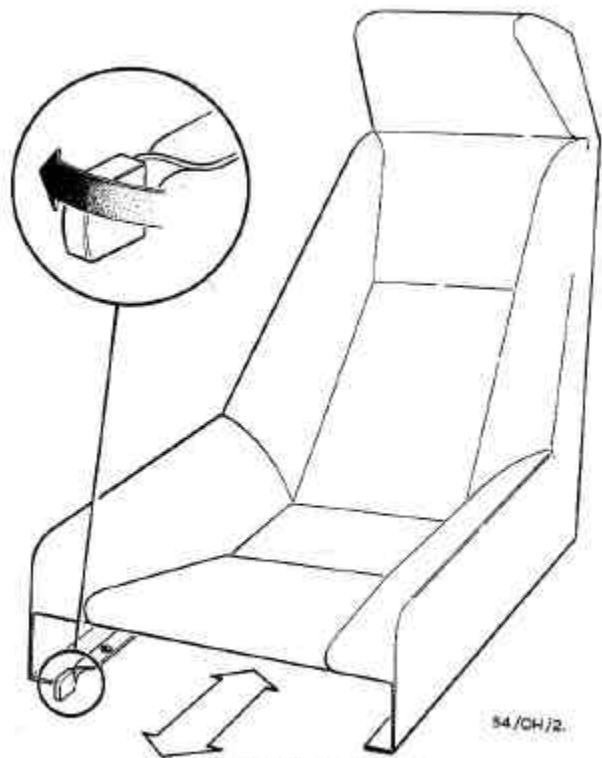

10

Fig. 2. Seat adjustment

engine, the accelerator pedal should be fully depressed and the starter operated. Release the accelerator pedal immediately the engine starts.

RUNNING-IN

The progressive "running-in" of a new engine and transmission is very important, to ensure that both give smooth performance, durability and economy throughout their life.

The process of "running-in" applies not only to the engine and transmission but also to many chassis components, and other moving parts. The process must be continued progressively for the first 2,000 km. (1,200 miles). It is important during the "running-in" period that the engine is not overloaded, as would occur when ascending hills in top gear at low speed; always make use of the gearbox. It should be remembered that the gearbox will not be "run-in" when constantly in top gear.

It is very important that the engine speed is kept moderate during the "running-in" period, both on the road, and when stationary. During the first 2,000 km. (1,200 miles) do NOT EXCEED an indicated engine speed of 3,000 r.p.m. on the tachometer.

On completion of the first 500 km. (300 miles), then at 2,000 km. (1,200 miles) take your car to

your Lotus Dealer so that the "free" services and inspections can be carried out.

SERVICING

The following information covers routine maintenance which you may be desirous of carrying out.

Battery (Negative earth)

The battery is accessible in the right-hand side of the rear luggage compartment and should be examined weekly to check the level of the electrolyte.

1) Remove the vent chamber cover and top up levels if they are below the bottoms of filling tubes.

2) Pour distilled water into the trough until all tubes are filled.

3) Immediately replace the cover to allow the water in the trough and tubes to flow into the cells. Each cell will automatically receive the correct amount of water.

4) Keep the battery and its surroundings clean and dry.

NOTE: As the battery is of the NEGATIVE earth type, it is important to note that when fitting electrical equipment of any description (i.e., radio), this also must be of negative earth polarity. Never connect a

12



Fig. 3. Front jack location



Fig. 4. Rear jack location

battery charger to the battery without first disconnecting the leads.

13

Using the jack

The jack should be located at the rear of each wheel arch, using the "L" shaped adaptor (in toolkit) on the head of the jack and between the car body depending on which wheel is being raised. Apply the handbrake before commencing to raise the vehicle. If parked on a slope, the wheels which are not being raised should be chocked.

ALWAYS store the jack in its correct location (see Fig. 5). If stored on the floor it could, in certain circumstances (such as cornering hard), puncture or craze the fibreglass side of the body.

Wheel removal

- 1) Remove the nave plate in the centre of the wheel with the aid of a screwdriver, inserting the blade between the wheel and the outer edge of the plate, and twisting off, using the wheel as a fulcrum
- 2) Using the wheel nut wrench, slacken the nuts a half-turn.
- 3) Raise the vehicle with the assistance of the jack.
- 4) Continue to release the wheel nuts, taking care not to damage the paint on the wheels.
- 5) Replace the wheel nuts by reversing these instructions.

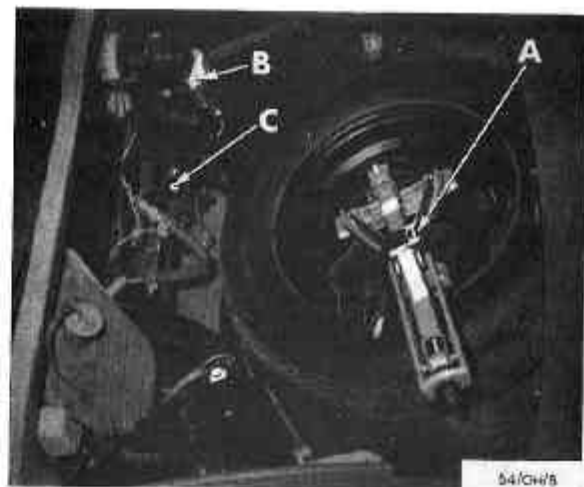

Fig. 5. A—Correct jack stowage
B—Brake master cylinder reservoir
C—Steering rack lubrication plug

- 6) Check security of wheel nuts every 1,600 km. (1,000 miles).

NOTE: All wheel nuts have right-hand threads and are removed in an anti-clockwise direction. When replacing nuts, ensure that their rounded ends are facing the wheel.

14

Tyres

It is recommended that the complete assemblies of wheels and tyres are balanced at intervals of every 5,000 km. (3,000 miles).

Maintain the tyres at the correct pressures. Under-inflation will cause excessive wear and rapid deterioration of the tyre walls, whilst over-inflation will have a detrimental effect on the handling characteristics. Pressures should be checked at least once a week.

Because of their light, precise steering, these cars are highly sensitive to tyre radial run-out and concentricity. If trouble is experienced with replacement tyres reference should be made to the tyre manufacturer concerned.

For the recommended tyre pressures which should be checked every 1,600 km. (1,000 miles), see specification section.

Frost precautions

To avoid the possibility of the cooling system freezing whilst the vehicle is stationary or whilst being driven in very cold weather, it is recommended that an anti-freeze obtainable from your Lotus Dealer should be used, and added in the quantities stipulated by the anti-freeze manufacturers.

We recommend anti-freeze based on inhibited ethylene glycol. Anti-freeze using alcohol as a

base is not suitable, as it is subject to loss by evaporation.

Owing to the difficulty in completely draining the heater system with normal draining of the engine cooling system, **it is essential that anti-freeze is used when cold conditions are anticipated.**

Body care

When washing the vehicle, use plenty of cold water; never attempt to remove dust or mud from the paintwork when dry, as this will damage the high gloss finish.

Special preparations are marketed for adding to the washing water; the use of these mild "detergents", as directed by the manufacturers, will expedite washing. Only use preparations of a reputable manufacture. When dust and mud have been removed with sponge, and water, finally dry with a chamois leather.

If the car is kept clean by frequent washing, it will be found that polishing is almost unnecessary.

The bodywork, can if desired be protected with a good soft wax polish, using a haze remover first to remove all "traffic film" and old polish.

Owners are warned that certain types of plastic and rubber covers can cause deterioration of any paintwork; before purchasing a cover, consult your LOTUS DEALER.

During the months of winter, many countries use salt to assist in the clearance of ice and snow. Thoroughly wash the coachwork, the underside of the body and wings, and the chassis, either weekly or more frequently, depending on local conditions, to remove any salt deposit and prevent its corrosive action. The fibreglass coachwork will not, of course, be affected by any corrosive action, but the metal parts attached could be.

Bright metal—The attractive appearance of bright metal can be preserved if it is cleaned regularly. Each week, wash with a soap and water solution, rinse thoroughly with clean water and dry off. Staining or tarnish can be removed with a good-quality chromium cleaner. For further protection, apply a good-quality wax polish.

Windscreen cleaning—The windscreen wiper is hinged so that it may be lifted clear of the glass, when cleaning the windscreen. Never push the blade across the windscreen as this will damage the mechanism.

Upholstery and roof lining—Normal cleaning consists of an occasional light wipe over with a cloth dampened in a mild soap and water solution; it is important that the cloth is only damp, not soaked.

Brakes

Pressure on the brake pedal forces fluid from a master cylinder into cylinders at the wheels, exerting pressure on pistons which actuate the front brake pads, or the rear brake shoes.

The handbrake is mechanically operated, through a cable linkage and operates on the rear brakes. It is quite independent of the hydraulic system in operation.

Brake adjustments—When properly adjusted there should be a 6 mm. ($\frac{1}{4}$ in.) free movement of the brake pedal before the piston in the brake master cylinder begins to move. When checking this setting take care that the carpets are not fouling the pedal.

No manual adjustment to compensate for brake pad wear is provided, or indeed necessary, since the correct pad-to-disc relationship is maintained hydrostatically as the brakes are operated.

Rear brakes can be adjusted by means of the square adjusters located on the brake backplates.

Brake pads and shoes—These should be examined at intervals of every 5,000 km. (3,000 miles), as shown in the Service Voucher Book (Part No. 46T 326) supplied with the car. If brakes are in constant use, as when driving in city traffic, it is advisable to examine at intervals of 1,600 km.

(1,000 miles). Always use genuine parts on replacement.

It should be understood that a metallic hiss is apparent with disc brakes. This is normal and should not be considered as a fault. If a metallic squeal is heard, this is general indication of brake pads OVERDUE for replacement. In the interests of safety see your Lotus Dealer without delay. Under no circumstances allow the pads to wear below 1.6 mm. (1/16 in.) thickness. They should therefore be renewed if of insufficient thickness to ensure safe braking for a further 5,000 km. (3,000 miles).

Servo unit air filter (if fitted)—Every 10,000 km. (6,000 miles) the filter element should be renewed.

To renew filter element, release central screw and remove cover to obtain access to the filter.

Bleeding the system—Bleeding the system to expel all air is not a routine maintenance operation and should only be necessary when some part of the system has been disconnected or fluid drained off, thereby allowing air to enter. We strongly recommend that this work be entrusted to your Lotus Dealer.

Hydraulic pipe connections—It is of vital importance that there are no leaks in the hydraulic system, therefore it is essential that these should be

checked periodically, when the brakes are receiving normal maintenance inspection. This work should be entrusted to your Lotus Dealer.

Brake seals, hoses and fluid—The brake manufacturers recommend that at intervals not EXCEEDING 65,000 km. (40,000 miles) or 3 years, whichever is reached first, that the braking system be completely overhauled and all washers, seals and hoses renewed. Hydraulic servo units should be stripped, all old seals discarded, component parts cleaned and examined and if in good condition, the unit rebuilt with the appropriate service kit.

It is also recommended that the brake fluid is renewed every 18 months. Additionally, if a continental journey (or similar long mileage trip) is being undertaken, it is recommended that the fluid is renewed, if this has not already been done within the previous 9 months.

In the interests of safety, all of the foregoing work should be entrusted to your Lotus Dealer who is fully equipped to carry out this work.

LUBRICATION

Regular lubrication is essential for long life and sustained performance, and the correct intervals

17

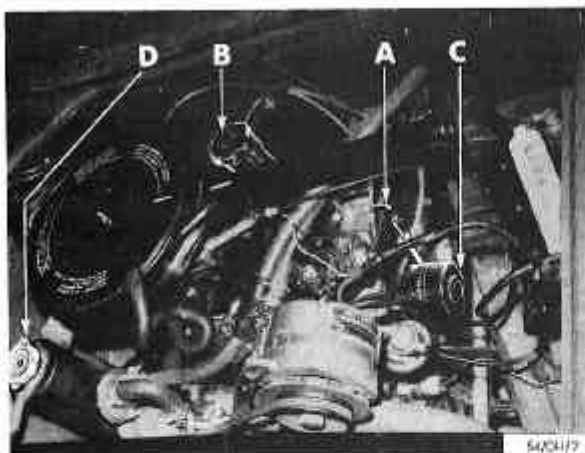

Fig. 6. A—Engine sump dipstick
B—Engine oil filler cap
C—Engine oil filter
D—Cooling system filler cap

for lubrication, as given in the Service Voucher Book (Part No. 46T 326) should be strictly followed. It is most important that only the grade of lubricant shown in the table is used, otherwise serious damage may result.

Recommended lubricants—see table page 22.

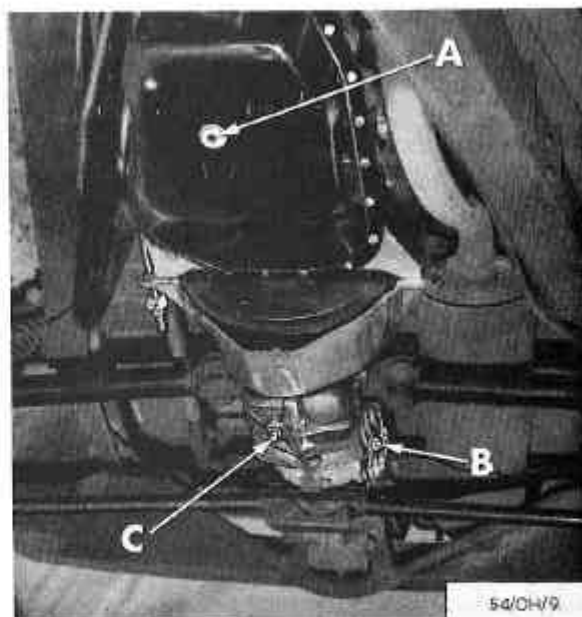

Fig. 7. A—Engine sump drain plug
B—Transmission filler/level plug
C—Transmission drain plug

18

Engine

The correct level is to the top mark on the dipstick, which is located to the right-hand side of the cylinder block. The oil filler cap is at the forward end of the rocker cover. Inspect the oil level daily, topping-up if necessary to the correct level. DO NOT overfill. Replace the oil filler cap securely otherwise an oil loss will occur and could result in a complete failure of the engine lubrication system.

Draining the sump—Draining of the sump will be greatly facilitated if carried out when the car has just completed a run and the oil is warm, thus flowing more readily. Allow to drain thoroughly, clean the drain plug and replace. Ensure that your garage attendant replaces the cap correctly.

The drain plug is located at the right-hand rear of the sump.

NOTE: If the engine oil is renewed at the recommended intervals there is no necessity to use a flushing oil. The use of a flushing oil is NOT recommended because of the difficulty in draining it completely.

Oil filter—It is recommended that the oil filter element be renewed at intervals of every 10,000 km. (6,000 miles).

It is pointed out that it is false economy to fit a new oil filter alone; always refill engine with new oil, after draining the sump.

Transmission

A combined filler/level plug is located on the left-hand side of the casing, while the drain plug is at the bottom of the casing. The oil level should be to the bottom of the filler plug orifice, and only oil of the correct grade added. Used lubricant should be drained at intervals of every 10,000 km. (6,000 miles) preferably when the oil is warm when the car has just completed a run, thus allowing it to flow more readily. Allow to drain thoroughly, clean the drain plug and replace.

Lower steering swivels

At intervals of every 10,000 km. (6,000 miles), remove the plug "A" (Fig. 8) and fit a screwed nipple. Apply a grease gun filled with 90 EP hypoid oil to the nipple and pump the gun until oil exudes from the swivel. Remove the nipple, refit the plug, and repeat with the opposite swivel.

Brake fluid reservoirs

The brake fluid reservoir is located in the front luggage compartment, on the driving side (see Fig. 5).

Check fluid level in the reservoir at intervals of every 5,000 km. (3,000 miles), topping-up if necessary to within 12 mm. ($\frac{1}{2}$ in.) of the top. Use only the specified fluid for topping-up.

19

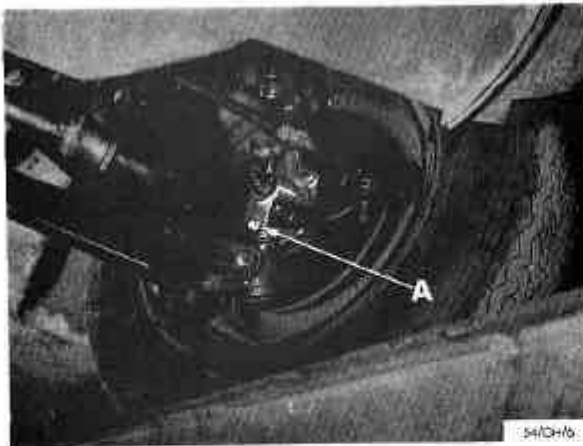

Fig. 8 A—Steering swivel plug

SERVICE NOTES

Storage

If you wish to store your car for a period, it is desirable to take certain precautions, otherwise damage may result.

Your Lotus Dealer will be pleased to give you assistance according to the length of time the car

will be out of use.

Lotus genuine parts

Lotus genuine spare parts are identical to the high-quality factory parts installed in new Lotus vehicles.

Always insist on Lotus genuine parts.

Radio suppression

For owners who are desirous of fitting a radio, we recommend that suppressors are also fitted, otherwise reception could be impaired by the fibreglass body.

It is suggested that all suppression is carried out by your Lotus Dealer.

Special Accessories

Special accessories are available for this car, and in some instances provision is made in the car for their fitting. Some of these accessories are:

- Safety belt kit
- Extra fuel tank
- Brake servo unit
- Radio.

Full details are available from your Lotus Dealer.

20

	SHELL	ESSO	B.P.	CASTROL	MOBIL
Engine (Above 0° C.)	Shell X-100 20W/50	Esso Extra 20W/50	Super Viscostatic 20W/50	Castrol GTX	Mobiloil Super
Engine (Below 0° C.)	Shell Super	Esso Extra 10W/30	Super Viscostatic	Castrolite	Mobiloil Special 10W/30
Transmission	Shell Spirax 80 EP	Esso Gear Oil GP 80	B.P. Gear Oil 80 EP	Castrol Hypoy Light	Mobilube GX 80
Grease points	Shell Retinax A	Esso Multi-purpose Grease	Energrease L.2	Castrolasee LM	Mobilgrease MP
Steering swivels	Shell Spirax 90 EP	Esso Gear Oil GP 90/140	B.P. Gear Oil SAE 90 EP	Castrol Hypoy	Mobilube GX 90
Brake master cylinder reservoir: Castrol Girling Brake and Clutch Fluid Crimson to specification SAE 70 R.3.					

22

Description

Front hubs
Repack with grease if necessary

Steering swivels
Lubricate

Steering rack
Lubricate

Drive shafts
Lubricate

Service

B,C

B,C

C

A,B,C

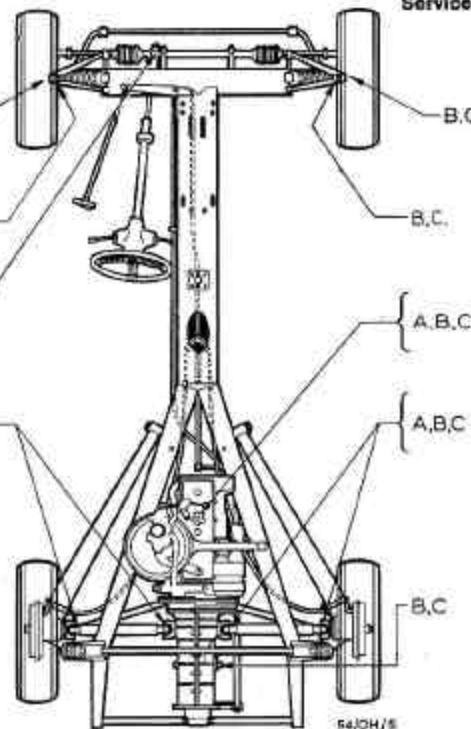

Service

B,C

B,C

A,B,C

A,B,C

Description

Front hubs
Repack with grease if necessary

Steering swivels
Lubricate

Engine
Check level daily
Drain when hot and refill

Drive shafts
Lubricate

Transmission
Check level at "A" service
Drain when hot and refill

Fig. 9. Lubrication diagram (use in conjunction with Service Voucher Book 46T 326)

23

TECHNICAL SPECIFICATION

ENGINE

Capacity	1470 cc. (89.7 cu. in.)
Type	Overhead valve
No. of cylinders	4
Bore	76 mm.
Stroke	81 mm.
Compression ratio	10.25:1
Firing order	1-3-4-2 (No. 1 at flywheel end)
Oil pressure (hot)	4.2 kg. cm. ² (60 lbs. in. ²)
Ignition timing (Static)	4° B.T.D.C.
Distributor contact breaker gap	.40/.50 mm. (.016/.019 in.)
Spark plug—Type*	Marchal 34 HS
—Gap	.60/.70 mm. (.025/.028 in.)

* The only type to be used.

VALVE CLEARANCES

Inlet	.20 mm. (.008 in.)
Exhaust	.25 mm. (.010 in.)

TRANSMISSION

Overall ratios (synchromesh on all forward gears).

Top	3.66:1
Third	5.26:1
Second	8.00:1
First	12.83:1

FRONT SUSPENSION

Front wheel toe-in	4.8 mm. (3/16 in.) to 1.6 mm. (1/16 in.)
Camber angle	0° to $\pm\frac{1}{2}$ °
Castor angle	3° $\pm\frac{1}{2}$ °
Swivel pin inclination	9° $\pm\frac{1}{2}$ °

REAR SUSPENSION

Rear wheel toe-in	4.8 mm. (3/16 in.) to zero
Camber angle	0° to 2° Negative

WHEELS AND TYRES

Wheel—Type	Pressed steel bolt-on
—Size	4 $\frac{1}{2}$ J
Tyres*—Type	Firestone F.100 tubeless, or Dunlop SP Sport with tubes*
—Size	155 x 13
Pressure—Front+	1.26 kg. cm. ² (18 lbs. in. ²)
—Rear+	1.96 kg. cm. ² (28 lbs. in. ²)

* If it is desired to fit inner tubes, it is essential that the correct type of inner tubes are used with radial ply tyres.

+ Increase by .28 kg. cm.² (4 lbs. in.²) for sustained fast touring or full load.

24

DIMENSIONS

Wheelbase	231.1 cm. (91 in.)
Track (at wheel hub)—Front	134.6 cm. (53 in.)
—Height	107.9 cm. (42 $\frac{1}{2}$ in.)
Overall—Length	399.4 cm. (157 $\frac{1}{2}$ in.)
—Width	163.8 cm. (64 $\frac{1}{2}$ in.)
—Height	107.9 cm. (42 $\frac{1}{2}$ in.)
Design ground clearance	16.5 cm. (6 $\frac{1}{2}$ in.)
Turning circle	13.4 m. (44 ft.)
Kerb weight (unladen)	710 kg. (1566 lbs.)

CAPACITIES

Fuel tank	34 litres (7 $\frac{1}{2}$ gall.; 9 US gall.)
Engine (with filter) oil	4 litres (7 $\frac{1}{2}$ pts.; 9 US pts.)
Transmission oil	1.75 litres (3 pts.; 3.6 US pts.)
Cooling system (with heater)	10.3 litres (18 pts.; 21.6 US pts.)
Battery (negative earth)	12 volt, 57 amp. hr.

25

FAULT DIAGNOSIS

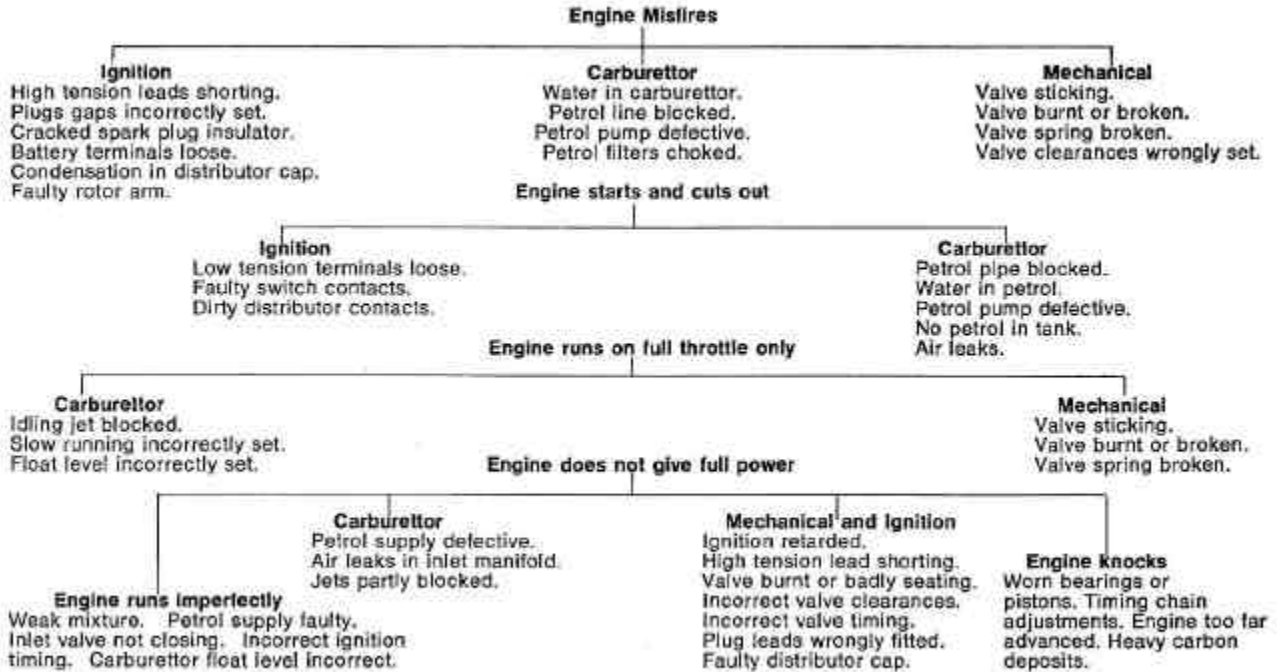

26

FAULT DIAGNOSIS

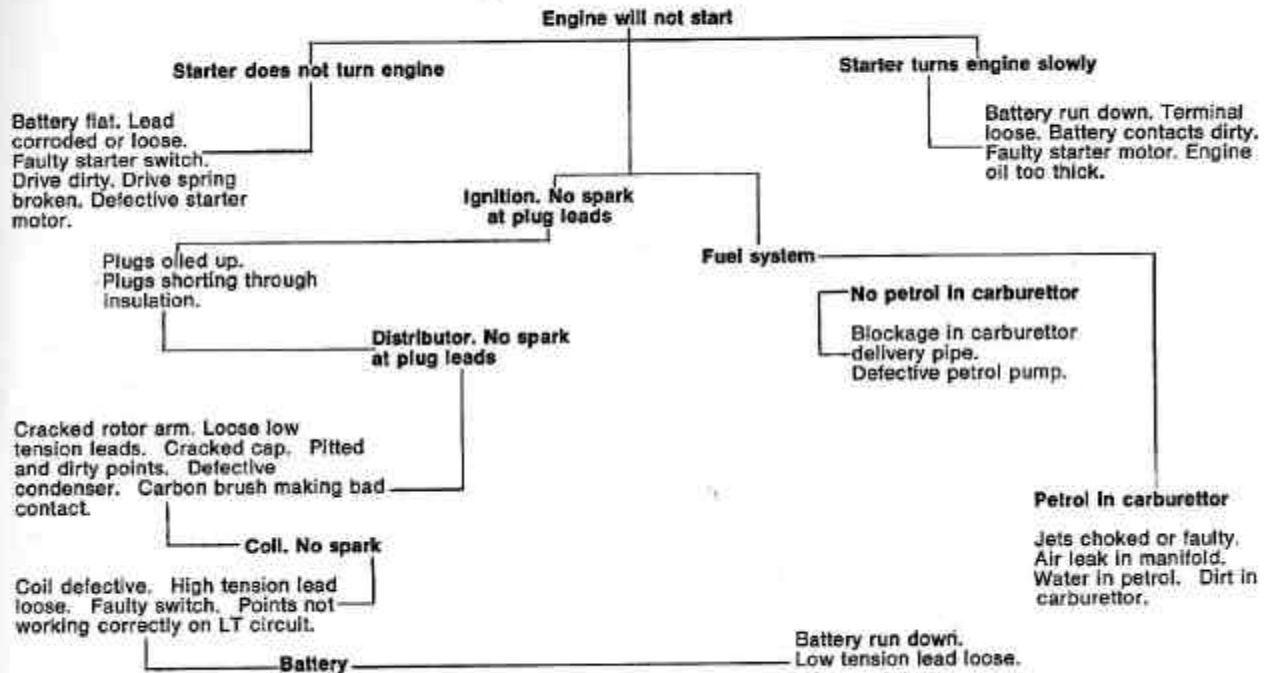

27

